

Multiloop Circuits: Kirchhoff's Rules.

Introduction

In this lab you will practice apply Kirchhoff's Rules to circuits containing more than one power supply and several possible current paths. Kirchhoff's Rules result when we apply conservation of energy and conservation of charge to a circuit. The resulting equations allow us to solve for the currents in various branches of a circuit.

Equipment

Protoboard	Resistors (~100-1000k)	Multimeter	Colored
Floating power supply	Wires, Alligator Clips		Pencils

Theory

Kirchhoff's Rules and **Ohm's Law** have already been discussed in previous labs.

Kirchoff's Rules:

Voltage Rule: The sum of voltage around a loop is zero ($\sum V = 0$). This is a statement of conservation of energy since changes in voltage (potential energy per charge) should add to zero around any closed loop in the circuit. Once you get back to your starting point the total change in voltage should add up to zero.

When Kirchoff's Rules are applied in a circuit, the signs of the voltage changes are particularly important. When the voltage changes are traced through a battery or power supply in the direction from minus to plus the potential increases. The potential supplied by a power source is called the EMF (electromotive force), \mathcal{E} . When a circuit is traced through a resistor *in the direction of the current* the potential decreases. According to **Ohm's Law** this voltage change is $V_R = I R$.

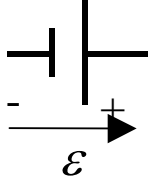
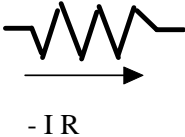
<p>\mathcal{E} (EMF) is positive going from - to + on a battery, negative going the other way</p> 	<p>Voltage ($V=IR$) is negative in the direction of current across a resistor, positive when you trace the circuit the other way.</p> 
--	--

Current Rule: A node is any junction in the circuit where the current can split into more than one path. The sum of current into a node is equal to the sum of current out of the node. ($\sum I_{in} = \sum I_{out}$). This is a statement of conservation of charge: the same amount of charge per second (current) must leave a junction in the wire as arrives. Charges are not created or destroyed in the circuit -- they simply circulate in the circuit gaining energy (from a power supply or battery) or losing energy (dissipated as heat in a resistor, for example).

Power in a circuit:

Power is defined as the *rate* of Energy gained or dissipated. This rate is given by

$$\text{Power: } P = I \cdot V$$

The equation is easy to understand since the voltage, V , is potential energy per charge and the current, I , is the charge per second passing through the circuit. The units of power are Watts (Joules/sec).

A source of EMF (battery or power supply) *supplies* power at the rate $P = I \cdot \mathcal{E}$ if the current passes through it in the direction from - to +. If current runs through a battery "backwards" from + to - then it *uses up* energy at the rate $P = -I \cdot \mathcal{E}$. This can be equivalent to recharging the battery.

A resistor dissipates energy as heat at the rate of $P = -I \cdot V = -I^2 \cdot R$.

Procedure

In this lab you will first apply Kirchoff's rules to analyze a circuit and predict the currents in the circuit. After making your prediction you will construct the circuit on the protoboard and check your predictions. Things to keep in mind as you analyze the circuit are:

Make sure the signs of your voltages changes are correct (see above).

In order to solve an algebraic problem with N unknown quantities you need N independent equations. The number of equations you end up with must be the same as the number of unknown currents in your circuit.

The equations must be *independent*. That is you should not be able to combine any two equations to form a third: each new equation must contain new information about the circuit. You will need both voltage (loop) equations and current (node) equations.

Circuit One:

This circuit may be constructed using two power supplies and three resistors. Choose resistors in the range of 100-1000 Ohms. If you use the protoboard supplies then the "negative" terminals do not exist -- the supplies are automatically referenced to ground. If you use external power supplies they may have both negative and positive terminals.

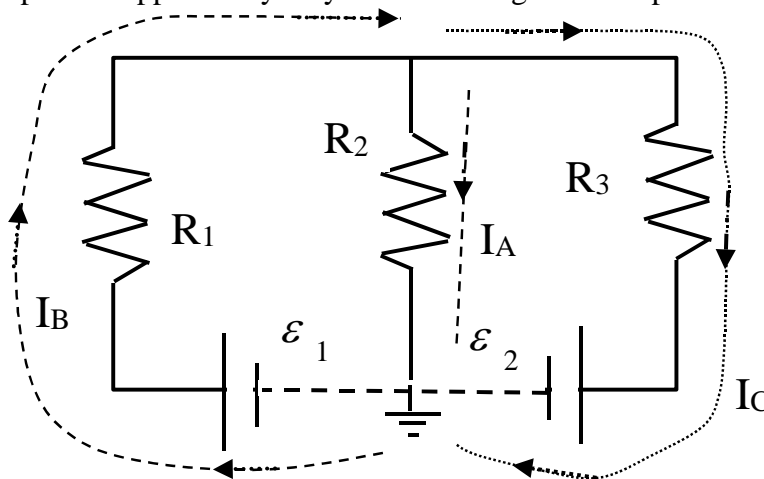

In the figure above the currents have already been drawn in and labeled. Directions for the currents were chosen arbitrarily. The current in the same in any path which does not have a

split (junction) in it. Current does not change going through resistors or power supplies -- only at junctions.

The circuit above has two nodes (shown by small circles). There is only one independent current equation. For the bottom node the current going in is $I_A + I_C$ and the current coming out is I_B . Thus

$$I_A + I_C = I_B \quad \text{(Equation One)}$$

The top node would give an equivalent equation since I_B comes in and I_A and I_C go out.

There are two independent loops in this circuit. Tracing the left loop clockwise starting at the lower left we get the equation

$$-I_B R_1 - I_A R_2 + \mathcal{E}_1 = 0 \quad \text{(Equation Two)}$$

Tracing the right loop clockwise starting at the lower right we get

$$-\mathcal{E}_2 + I_A R_2 - I_C R_3 = 0 \quad \text{(Equation Three)}$$

The voltage differences are positive going through the battery minus to plus and negative going through the resistor in the direction of the current.

If we trace the circuit around the outside circle we would get the equation:

$$-\mathcal{E}_2 + \mathcal{E}_1 - I_B R_1 - I_C R_3 = 0$$

This is not independent however, since we could obtain it by adding Equations 2 and 3. There are three independent (one current and two voltage) equations and three unknown currents so it is possible to solve for the currents. From equations (2) and (3) both I_B and I_C could be written in terms of I_A . These expressions could be used in Equation (1) to write an equation with only I_A in it. Once this was found it would be possible to go back and find I_B and I_C to show that:

$$I_A = \frac{\mathcal{E}_1 R_3 + \mathcal{E}_2 R_1}{R_1 R_2 + R_1 R_3 + R_2 R_3} \quad \text{and} \quad I_B = \frac{\mathcal{E}_1 R_3 + \mathcal{E}_1 R_2 - \mathcal{E}_2 R_2}{R_1 R_2 + R_1 R_3 + R_2 R_3} \quad \text{and} \quad I_C = \frac{\mathcal{E}_1 R_2 - \mathcal{E}_2 R_1 - \mathcal{E}_2 R_2}{R_1 R_2 + R_1 R_3 + R_2 R_3}$$

In your report

Construct this circuit using the protoboard and either internal or external power supplies. Use resistors from 100 to 1000 Ohms and the 5V and variable voltage power supplies. Make a sketch of your circuit and label all the power supplies and resistors with symbols *including subscripts*. Next to the sketch make a table showing the values you are using for power supplies and resistors. You can use colored pencils to color-code the different currents in your circuit. Indicate the labels for the currents as well.

Trace the circuit and measure the voltage differences across the power supplies and resistors.

The power supplies on the protoboard are referenced to ground. *Be careful of polarity -- your multimeter reads voltage differences between its two terminals. Put the leads in the same order as you are tracing your circuit.*

Record the voltage differences on your sketch. Indicate the direction you measured (with an arrow) and the sign of the voltage.

Determine whether the sum of voltage differences around any loop add to zero.

Below your sketch write the appropriate voltage equations -- first with symbols (including subscripts) then with the values you have measured.

Use the ammeter to measure all the currents in your circuit. Again, the meter can tell you the direction of the current by its sign.

Record the currents on your sketch with arrows showing the direction.

Do the currents into each node add up to the currents coming out?

Calculate the power supplied or dissipated in the circuit.

Does power supplies equal power dissipated?

Compare measured currents to values calculated by solving Kirchhoff's equations. Show and label your work clearly.

RECOPY YOUR SKETCH AND DATA IF NECESSARY TO MAKE THEM NEAT AND READABLE!!!

Circuit Two:

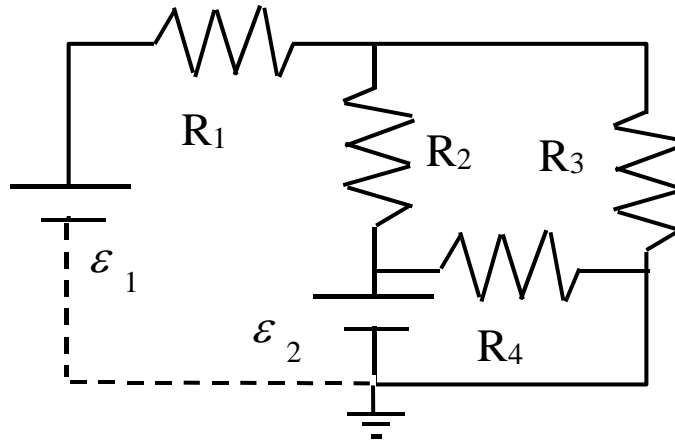

Add another resistor. Make a sketch, labeling and color coding everything as before.

Choose directions and label and color-code the currents in this circuit

There will be one less independent current equation in this circuit than there are nodes.

Write out the independent current equations.

How many independent loops are in this circuit? You have found all of them if the loops you have used have traced every wire. Write out the voltage equations.

You don't have to solve this one! Can you solve it (in principle) -- are there as many equations as you have unknown currents?

Measure the currents in this circuit. Pay careful attention to their directions. Record the data on your sketch.

Are the current node equations upheld? Write them out with both symbols and with numbers.

Are the voltage loop equations upheld? Use the currents you have measured to calculate the voltage across the resistors and check the loop equations. Again, be careful of directions!

Is energy conserved in this circuit (power supplied \Rightarrow power dissipated). Show and explain your calculations.

RECOPY YOUR SKETCH AND DATA IF NECESSARY TO MAKE THEM NEAT AND READABLE!!!