

Rearing Its Ugly Head: The Cosmological Constant and Newton's Greatest Blunder

Hieu D. Nguyen

A clever man commits no minor blunders. ---- Johann Wolfgang Von Goethe (1749 - 1832)

1 INTRODUCTION

It is folklore that Albert Einstein's greatest blunder occurred in 1917 when he introduced the *cosmological constant* term into his theory of general relativity [5]. At the time Einstein believed the universe to be static, and yet his original field equations, which describe how the gravitational influence of matter bends space-time, predicted an expanding (or contracting) one. To resolve this apparent contradiction and counteract the effects of gravity, Einstein introduced into his equations an all-encompassing force term scaled by a constant Λ (originally λ) that has become known as the cosmological constant [19]. Then along came Edwin Hubble's observation of galactic red shifts in 1929, which evidenced an expanding universe and made Einstein's cosmological constant term unnecessary. Einstein thus realized he had missed a great opportunity to predict the expansion of the universe from his original theory, had he only believed in it. As recounted by the cosmologist George Gamow in his 1970 autobiography [4]:

...Thus, Einstein's original gravity equation was correct, and changing it was a mistake. Much later, when I was discussing cosmological problems with Einstein, he remarked that the introduction of the cosmological constant term was the biggest blunder he ever made in his life. But this "blunder," rejected by Einstein, is still sometimes used by cosmologists even today, and the cosmological constant denoted by the Greek letter Λ rears its ugly head again and again and again.

For decades Gamow's quote fueled controversy surrounding whether Einstein really made such a remark. As Harvey and Schucking point out in [6], Gamow "had a well-established reputation as a jokester and given to hyperbole." Yet even if Gamow's recollection about Einstein may have been exaggerated, he was quite prescient in his other remark about the cosmological constant – it continues to play an ever increasing role in general relativity (and yes even in quantum mechanics), rearing its 'ugly' head in many leading theories to account for the increasing expansion of the universe and the existence of dark energy and vacuum energy. Indeed, a good account of these theories for the lay reader is given by David Goldfield in his book [5], who amusingly refers to the cosmological constant as one of many *fudge factors* used in physics.

In this article we travel back in time to the birth of celestial mechanics, some 230 years before Einstein's biggest blunder, to argue that his was not the first instance in which the cosmological constant reared its ugly head. Much less well known in the scientific community is the story of Isaac Newton, who made a similar blunder in the *Principia* (Mathematical Principles of Natural Philosophy) [10] by introducing an *extraneous force* into his lunar theory to explain the advance of the moon's apsis, or line

of extreme position, as it orbits the earth (see [22]). Newton took this effect to be due to the radial attraction of the sun as a third body in the first known mathematical attack on the three-body problem but modeled it incorrectly using Jeremy Horrocks's theory of revolving orbits [21]. His biggest blunder, however, was to treat the solar attraction as a harmonic force term, which we demonstrate later in this article is equivalent to Einstein's cosmological constant term from the perspective of Newtonian mechanics. As a result, Newton failed to achieve the correct answer for the moon's precession, obtaining only half the observed value, or as Newton himself comments at the end of Section IX of the *Principia* (third edition), "The apse of the moon is about twice as swift." A more accurate calculation would only be given in 1756 (after Newton's death) by A.C. Clairaut, who generalized Newton's work by assuming a lunar orbit with incommensurable periodic terms [3].

Even though Newton failed to mathematically explain apsidal precession of the moon, his method for calculating it clearly demonstrated his mastery of the new calculus. As we reveal in this article, the key result behind Newton's method is his remarkable Revolving Orbit Theorem in the *Principia* (Proposition 44, Theorem 14). In it he demonstrates how two central force laws must differ by an inverse-cube radial term if their orbits are such that one is a revolving orbit of the other. This fact allowed him to study the motion of nearly circular orbits by approximating them as revolving elliptical orbits, a case where he was able to calculate precession precisely using his Theorem.

Sadly, as Chandrasekhar points out in [2], Newton's beautiful Revolving Orbit Theorem does not seem to be well known by the mathematical community. The reason may be that anyone who attempts to read the *Principia* will find the task daunting, as Newton provides geometrical proofs of his Theorem using language that now seems to us rather verbose. Fortunately, an accessible modern treatment of Newton's work can be found in [2], where an elementary calculus proof of his Theorem that requires using only the Chain Rule is given. In this article, we present this modern proof and demonstrate Newton's calculation of precession of the lunar apsis based on his theory of infinite series. Our treatment is quite accessible to undergraduate students and ideal as an application topic in a sophomore-level differential equations course. We then demonstrate how Newton's method can also be used to calculate (correctly this time) the perihelion precession of Mercury based on general relativity, one of its hallmark tests, as shown in [13]. We also argue that Newton's extraneous force term, which represents a linear expansive force, is in fact equivalent to Einstein's cosmological constant term taken as a weak-field approximation in general relativity. Lastly, we present a second-order generalization of Newton's method where we employ revolving general relativistic (as oppose to elliptical) orbits to approximate nearly circular orbits and calculate precession of their apsides.

2 PLANETARY MOTION

The *Principia* is unarguably one of the greatest achievements in mathematical physics. In it Newton derives Kepler's laws of planetary motion assuming an inverse-square law for gravity, a conjecture that Robert Hooke presented to him by letter in 1679 ([16], p. 297). To explain, let us assume that the gravitational attraction between two masses, denoted by M and m and separated by a distance r , obeys an inverse-square central force law

(modern convention calls for an attractive force to have negative value but we will instead follow Newton's convention and assume it to be positive):

$$F(r) = \frac{GMm}{r^2}. \quad (2.1)$$

Here, $G = 6.67 \times 10^{-11} \text{ m}^3 / \text{kg} / \text{s}^2$ is the universal gravitational constant. Newton was then able to prove using geometric arguments that the orbit of m about M (the latter assumed to be fixed) must indeed follow the shape of an ellipse (or more generally a conic section) as Kepler had proclaimed in his first law (see Figure 1) [12].

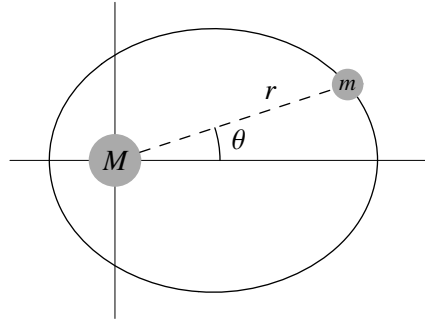

Figure 1 – Elliptical orbit

Of course, the modern approach to the two-body problem is to equate Newton's second law of motion, i.e., $F = ma$, with his gravity law given by (2.1) to derive the corresponding equation of motion. This is expressed in polar coordinates r and θ as

$$\frac{GM}{r^2} = \frac{d^2r}{dt^2} - r\omega^2, \quad (2.2)$$

where the right-hand side represents the normal (radial) acceleration a , and $\omega = d\theta/dt$ is the angular velocity of m . Then using the fact that $h = r^2 d\theta/dt$ represents the conserved angular momentum of m , we can rewrite (2.2) as

$$\frac{GM}{r^2} = \frac{d^2r}{dt^2} - \frac{h^2}{r^3}. \quad (2.3)$$

We note that h also represents geometrically (twice) the constant rate of area swept out by the radial line segment between M and m (Kepler's second law) since

$$\frac{dA}{dt} = \frac{d}{dt} \left[\frac{1}{2} \int_{\alpha}^{\theta} r(\bar{\theta})^2 d\bar{\theta} \right] = \frac{1}{2} r^2 \frac{d\theta}{dt} = \frac{1}{2} h. \quad (2.4)$$

Now, equation (2.3) can in fact be linearized if we use inverted polar coordinates, $u = 1/r$ and θ :

$$\frac{d^2u}{d\theta^2} + u = \frac{GM}{h^2}. \quad (2.5)$$

The solution to (2.5) is given by

$$u(\theta) = \frac{GM}{h^2} + B \cos(\theta - \theta_0), \quad (2.6)$$

where B and θ_0 are constants depending on initial conditions. The corresponding solution for r describes a conic section as claimed:

$$r(\theta) = \frac{R}{1 + e \cos(\theta - \theta_0)}. \quad (2.7)$$

Here, $e = Bh^2 / (GM)$ describes the eccentricity of the orbit and $R = h^2 / (GM)$ the focal parameter. If e is strictly between 0 and 1, then the orbit is elliptical and R gives the length of its semi-latus rectum. Moreover, $R = a(1 - e^2)$, where a is the length of the semi-major axis of the ellipse.

3 NEWTON'S REVOLVING ORBIT THEOREM

The notion that gravity is described by an inverse-square power law was a controversial one during Newton's time. Newton therefore devoted much effort in the Principia convincing the reader how the motion of bodies governed by this force law must be elliptical (and vice-versa). Moreover, he emphasized the point that any central force law that deviates from this inverse-square law would cause the line of apsis, i.e., the line of extreme position between M and m , to rotate about M by some amount after each revolution. This is evident from his comment following Proposition 2, Theorem 2, Book III:

[The inverse-square law] is proved with great exactness from the fact that the aphelia are at rest. For the slightest departure from the ratio of the square would (by book 1, prop. 45, corol.1) necessarily result in a noticeable motion of the apsides in a single revolution and an immense such motion in many revolutions.

Figure 2 illustrates how the apsis OP for the revolving elliptical orbit in solid has moved to OP' after one revolution in comparison to the fixed elliptical orbit (dashed). In general this amount of rotation per revolution, called *precession* and denoted by ϕ , cannot be calculated exactly since the solution to the corresponding equation of motion for a body acted upon by an *arbitrary* force law $F(r)$,

$$\frac{d^2u}{d\theta^2} + u = \frac{F(u)}{h^2u^2}, \quad (3.1)$$

requires the evaluation of an elliptic integral.

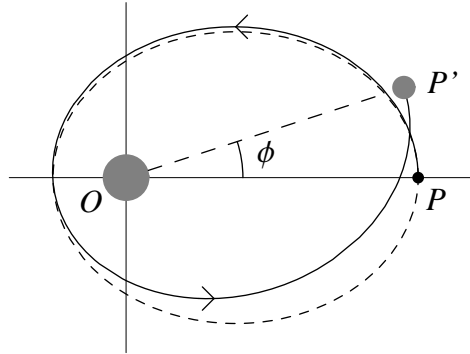

Figure 2 – Precession of the apsis

However, not so well known is the case where precession is very easy to calculate, in particular when the orbit is traced out by a revolving ellipse. In this regard Newton poses the following problem in Book I of the Principia:

Proposition 43 Problem 30

It is required to find the force that makes a body capable of moving in any trajectory that is revolving about the center of forces in the same way as another body in that same trajectory at rest.

To explain what Newton means by a revolving orbit (or trajectory), consider two objects of equal mass, m and \tilde{m} , that are released into their respective orbits (see Figure 3a), the former following a fixed elliptical orbit (in solid) and the latter a revolving elliptical orbit (in bold) in the sense that their radial distances are always equal and their angles θ and $\tilde{\theta} = \alpha\theta$, respectively, always maintain a fixed ratio α at all times. The position of \tilde{m} can therefore be interpreted as that on a rotating ellipse (dashed) with angle of rotation specified by $\omega = \alpha\theta - \theta$.

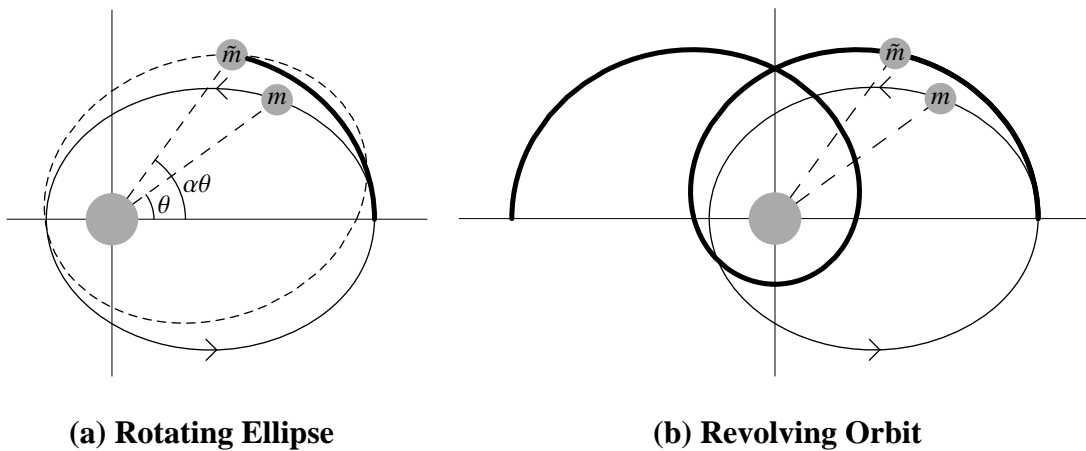

Figure 3

Figure 3b shows the revolving orbit (in bold) after one revolution of the fixed orbit assuming for example $\alpha = 1.5$ and corresponds therefore to a precession of

$$\phi = \omega \Big|_{\theta=2\pi} = 2\pi\alpha - 2\pi = 2\pi(1.5) - 2\pi = \pi . \quad (3.2)$$

To translate Proposition 43 into mathematical terms, suppose $r = f(\theta)$ describes the orbit of mass m under an arbitrary central force law $F(r)$, and define $r = \tilde{f}(\tilde{\theta})$ to be a *revolving* orbit of $f(\theta)$ in the sense that $\tilde{\theta} = \alpha\theta$ and

$$\tilde{f}(\tilde{\theta}) = f(\theta), \quad (3.3)$$

where α is a fixed parameter. Newton's problem can now be reformulated as follows: Is the revolving orbit $r = \tilde{f}(\tilde{\theta})$ also governed by a central force law $\tilde{F}(r)$, and if so how does it compare with $F(r)$? In Book I of the Principia, Newton gives the solution through his Revolving Orbit Theorem, which reveals how the force law of one orbit compares with that of a revolving one.

Proposition 44 Theorem 14

The difference between the forces under the action of which two bodies are able to move equally—one in an orbit that is at rest and the other in an identical orbit that is revolving—is inversely as the cube of their common height.

The following is a modern version of the above theorem.

Revolving Orbit Theorem: Let $r = f(\theta)$ denote the orbit of a mass with angular momentum h and governed by a central force law $F(r)$. Then the revolving orbit $r = \tilde{f}(\tilde{\theta}) = f(\theta)$, where $\tilde{\theta} = \alpha\theta$, represents the motion of the same object under the central force law

$$\tilde{F}(r) = F(r) + \frac{\tilde{h}^2 - h^2}{r^3}. \quad (3.4)$$

with corresponding angular momentum $\tilde{h} = \alpha h$, and conversely.

To prove this theorem we first observe that, as we have already seen, an orbit $r = f(\theta)$ governed by $F(r)$ satisfies the equation of motion given in (3.1) with $u = 1/r$. As Chandrasekhar demonstrates in [2], it is now a straightforward application of the chain rule to verify that $r = \tilde{f}(\tilde{\theta}) = f(\theta)$, where $\tilde{\theta} = \alpha\theta$, must satisfy the corresponding equation of motion:

$$\begin{aligned}
\frac{d^2u}{d\tilde{\theta}^2} + u &= \frac{1}{\alpha^2} \frac{d^2u}{d\theta^2} + u = \frac{1}{\alpha^2} \left(\frac{d^2u}{d\theta^2} + u \right) + \left(1 - \frac{1}{\alpha^2} \right) u \\
&= \frac{1}{\alpha^2} \frac{F(u)}{h^2 u^2} + \left(1 - \frac{1}{\alpha^2} \right) u = \frac{F(u) + (\tilde{h}^2 - h^2) u^3}{\tilde{h}^2 u^2} \\
&= \frac{\tilde{F}(u)}{\tilde{h}^2 u^2},
\end{aligned} \tag{3.5}$$

where

$$\tilde{F}(u) = F(u) + (\tilde{h}^2 - h^2) u^3. \tag{3.6}$$

Hence, $r = \tilde{f}(\tilde{\theta})$ is governed by the central force law

$$\tilde{F}(r) = F(r) + \frac{\tilde{h}^2 - h^2}{r^3} \tag{3.7}$$

as claimed.

4 PRECESSION OF THE LUNAR APSIS

It was well known during Newton's time that the orbit of the moon around the earth is not precisely elliptical (as dictated by the inverse-square law) but deviates slightly from this, which Newton viewed as a perturbation due to the attraction of a third body, i.e., the sun. He believed that anomalies in the moon's motion could be explained by modeling this perturbation as an additional central force. Towards this end Newton poses in Book I of the Principia the following general problem in his attempt to calculate apsidal precession of the moon's orbit:

Proposition 45 Problem 31

It is required to find the motions of the apsides of orbits that differ very little from circles.

His approach is to approximate nearly circular orbits by revolving elliptical orbits, a model that was already proposed by Jeremy Horrocks in 1632 to explain lunar precession [21]. Since the latter orbits are dictated by his Revolving Orbit Theorem, this allowed Newton to calculate precession as a first-order approximation.

Following [2], we define $r = f_N(\theta)$ to be an elliptical orbit described by the inverse square force law (per unit mass)

$$F_N(r) = \frac{h^2 / R}{r^2},$$

where $h^2 / R = GM$ and R is the semi-latus rectum of the ellipse. It follows from Newton's Theorem that the revolving orbit $r = \tilde{f}_N(\tilde{\theta}) = f_N(\theta)$, where $\tilde{\theta} = \alpha\theta$, obeys the force law (per unit mass)

$$\tilde{F}_N(r) = \frac{h^2 / R}{r^2} + \frac{\tilde{h}^2 - h^2}{r^3} = \frac{h^2 r / R + (\tilde{h}^2 - h^2)}{r^3}. \quad (4.1)$$

Now let $F(r)$ be an arbitrary central force law in the form

$$F(r) = \frac{C(r)}{r^3} \quad (4.2)$$

and assume that $r = f(\theta)$ is a nearly circular orbit governed by $F(r)$, i.e., an orbit with relatively small eccentricity, as illustrated in Figure 4.

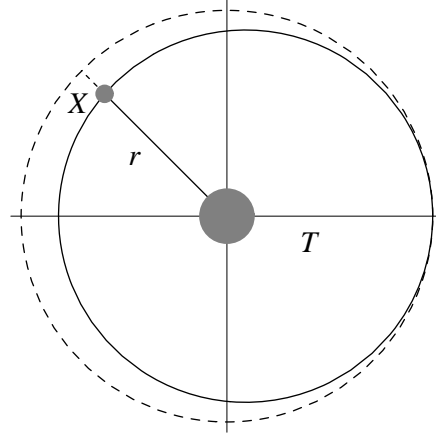

Figure 4 – Nearly circular orbit

Next, write $r = T - X$ where T is the mean distance (or length of the semi-major axis for an elliptical orbit) and X by assumption is relatively small. It follows that $F(r)$ can be approximated to first order (linear) in X as

$$F(r) = \frac{C(T - X)}{r^3} \approx \frac{C(T) - C'(T)X}{r^3}. \quad (4.3)$$

Similarly, we can rewrite (4.1) as

$$\tilde{F}_N(r) = \frac{h^2(T - X) / R + (\tilde{h}^2 - h^2)}{r^3}. \quad (4.4)$$

This can be simplified further by setting $R = T$, which Newton assumed to be valid for nearly circular orbits:

$$\tilde{F}_N(r) = \frac{\tilde{h}^2 - h^2 X / T}{r^3}. \quad (4.5)$$

Then from the approximation $F(r) \approx \tilde{F}_N(r)$, we can equate the numerators of (4.3) and (4.4) to yield

$$\begin{aligned} C(T) &= \tilde{h}^2, \\ C'(T) &= h^2 / T. \end{aligned}$$

Hence, we obtain the following formula for apsidal precession ([2], p. 194):

$$\alpha^2 = \frac{\tilde{h}^2}{h^2} = \frac{C(T)}{TC'(T)}. \quad (4.6)$$

A few remarks are in order:

1. Newton does not actually derive the general formula (4.6); however it is clear that he recognized it through his calculation of α^2 for several particular force laws, which we discuss in the examples below. Also, Newton makes the substitution $T = 1$ in his formulas for α^2 , which seems to have been done in order to simplify his calculations later on in the Principia when he considers precession of the lunar apsis. We shall not follow him in this regard.
2. The assumption that the given orbit $r = f(\theta)$ be nearly circular is crucial in order to approximate it accurately by a revolving elliptical orbit having the same initial conditions. Figures 5a and 5b illustrate how for $C(r) = r^{0.7}$ the revolving elliptical orbit (dashed) yields a worse approximation to the exact orbit (in solid) when the eccentricity, $e = (r_{\max} - r_{\min}) / (r_{\max} + r_{\min})$, is doubled.

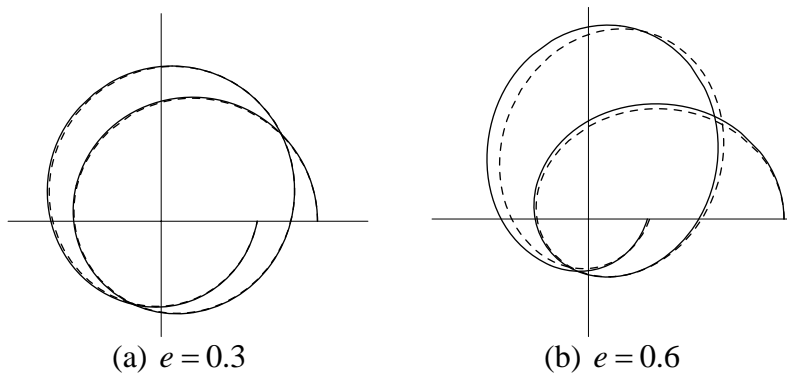

Figure 5 – Approximation of nearly circular orbit by a revolving elliptical orbit

3. A higher-order generalization of (4.6) can be obtained if we use the relation $R = T(1 - e^2)$, which holds for an elliptical orbit with eccentricity e , instead of the approximation $R = T$ that Newton makes. Up to second order in e , we have

$$\alpha^2 = \frac{\tilde{h}^2}{h^2} = \frac{\frac{C(T)}{TC'(T)} - e^2}{1 - e^2} \approx \frac{C(T)}{TC'(T)} + \left(\frac{C(T)}{TC'(T)} - 1 \right) e^2. \quad (4.7)$$

Let us now explicitly calculate precession for some particular force laws using (4.6).

Example 1: Assume that $F(r)$ takes on a monomial power law of the form

$$C(r) = ar^n, \quad (4.8)$$

where a is an arbitrary constant. Then

$$\alpha = \sqrt{\left| \frac{C(T)}{TC'(T)} \right|} = \sqrt{\left| \frac{aT^n}{T(naT^{n-1})} \right|} = \frac{1}{\sqrt{|n|}}. \quad (4.9)$$

Therefore, the amount of precession per orbit is

$$\phi = 2\pi \left(\frac{1}{\sqrt{|n|}} - 1 \right). \quad (4.10)$$

It follows that higher power laws produce greater precession. Examples of graphs of revolving orbits and their precessions are shown in Figure 6 for several particular values of n . Each should be compared with the corresponding fixed elliptical orbit (dashed) for the case $n = 1$.

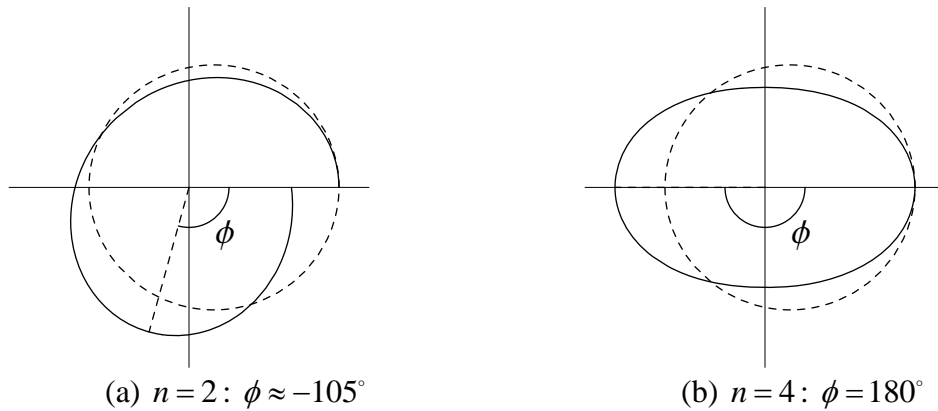

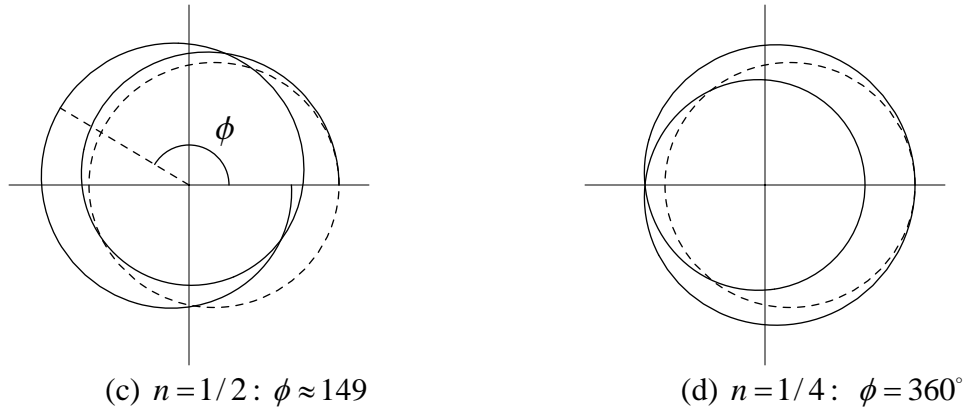

Figure 6 – Precession for Power Law $C(r) = ar^n$

Example 2: Assume $F(r)$ to be a binomial of the form

$$C(r) = ar^m + br^n, \quad (4.11)$$

where a and b are arbitrary constants. Then

$$\alpha = \sqrt{\left| \frac{C(T)}{TC'(T)} \right|} = \sqrt{\left| \frac{aT^m + bT^n}{maT^m + nbT^n} \right|}. \quad (4.12)$$

We now show how Newton employed (4.12) to calculate the precession of the lunar apsides. To this end, assume the moon is subject to an extraneous force¹ that is a perturbation of the inverse-square law:

$$F_c(r) = GM \left(\frac{1}{r^2} - cr \right). \quad (4.13)$$

Here, c is such that the ratio between the force of gravity and Newton's extraneous force² when $r = T$ satisfies

$$\frac{cT}{1/T^2} = \frac{100}{35745}, \quad (4.14)$$

or equivalently,

¹ This extraneous force Newton assumed to be due to the radial attraction of the sun even though he never explicitly mentions it, most likely because it failed to provide him with the correct value for the moon's apsidal precession.

² For a discussion as to how Newton obtained the ratio c for his extraneous force, see [22].

$$c = \frac{100}{35745T^3}. \quad (4.15)$$

Putting (4.13) into standard form (4.3) yields

$$C(T) = GM(T - cT^4) \quad (4.16)$$

We then apply (4.12) with $a = GM, b = GMc, m = 1$ and $n = 4$ to obtain

$$\alpha = \sqrt{\frac{T - cT^4}{T - 4cT^4}} \approx 1 + \frac{3cT^3}{2}. \quad (4.17)$$

The resulting precession is

$$\begin{aligned} \phi &= 2\pi(\alpha - 1) = 3\pi cT^3 \\ &= \frac{300\pi}{35745} \approx 0.026 \text{ rad} \\ &\approx 1.5^\circ. \end{aligned} \quad (4.18)$$

As noted earlier, Newton knew this answer to be incorrect in comparison to the observed value of approximately 3° per revolution. He would not live to see the correct theory for lunar precession, thus making this a rare mathematical failure for one of the greatest minds that ever lived. However, his blunder in introducing an extraneous force paved the way for Einstein to introduce a cosmological force into his theory of general relativity, which we discuss next.

5 GENERAL RELATIVITY AND PRECESSION OF MERCURY

It is well established that Einstein's theory of general relativity describes the motion of planets and other celestial bodies more accurately than Newton's theory of gravity. According to Einstein, the curvature of any region of four-dimensional space-time is affected by the presence of matter in it. This relationship is governed by his field equations ([19])

$$R_{ij} - \frac{1}{2}Rg_{ij} = 8\pi T_{ij}, \quad (5.1)$$

where $ds^2 = g_{ij}dx_i dx_j$ is a Lorentzian metric that describes the geometry of the region of interest, R_{ij} is the Ricci curvature tensor, R the scalar curvature, and T_{ij} the stress-energy momentum tensor that describes the distribution of matter in the region. The solution to (5.1) for a region that contains only a static spherically symmetric object of mass M is given in spherical coordinates by the Schwarzschild metric:

$$ds^2 = -\left(1 - \frac{2MG}{r}\right) dt^2 + \frac{1}{\left(1 - \frac{2MG}{r}\right)} dr^2 + r^2 d\theta^2 + r^2 \sin^2 \theta d\phi^2. \quad (5.2)$$

To connect this with Newtonian theory, we look for a potential Φ generated by the gravitational field described by (5.2). For a test particle of mass m moving slowly through this field, which we assume to be relatively weak, such a potential is related to the metric term $g_{00} = -(1 - 2GM/r)$ in the Schwarzschild metric as follows ([19], p. 78):

$$\Phi = \frac{g_{00} + 1}{2} = \frac{MG}{r}. \quad (5.3)$$

This is precisely the potential that yields Newton's inverse-square law for gravity:

$$F = -m \frac{d\Phi}{dr} = \frac{GMm}{r^2}. \quad (5.4)$$

To see how this differs from general relativity, we consider the notion of *effective* potential for our test particle. To this end, recall that the equation of motion given by (2.3) can be integrated to express conservation of energy as

$$\frac{1}{2} \left(\frac{dr}{dt} \right)^2 + \left(\frac{GM}{r} - \frac{h^2}{2r^2} \right) = E. \quad (5.5)$$

We identify

$$V_e = \frac{GM}{r} - \frac{h^2}{2r^2} \quad (5.6)$$

in (5.6) as the effective Newtonian potential with centrifugal term $h^2/(2r^2)$ and the constant of integration E as the total conserved energy. However, the actual equation of motion derived from the Schwarzschild metric is found to be ([18], p. 139)

$$\frac{1}{2} \left(\frac{dr}{dt} \right)^2 + \left(\frac{GM}{r} - \frac{h^2}{2r^2} + \frac{MGh^2}{c^2 r^3} \right) = E. \quad (5.7)$$

Thus we see that the effective general relativistic potential

$$V_e = \frac{GM}{r} - \frac{h^2}{2r^2} + \frac{MGh^2}{c^2 r^3} \quad (5.8)$$

contains an additional term, $Mgh^2/(c^2r^3)$, which is significant for relatively small r . This leads to the general relativistic force law (per unit mass)

$$F_E(r) = \frac{GM}{r^2} + \frac{3GMh^2}{c^2r^4}. \quad (5.9)$$

To calculate the amount of precession due to $F_E(r)$, we apply formula (4.12) in Example 2 by setting $a = GM$, $b = 3GMh^2/c^2$, $n = 1$ and $m = -1$:

$$\alpha = \sqrt{\frac{GMT + 3GMh^2/(c^2T)}{GMT - 3GMh^2/(c^2T)}} \approx \sqrt{1 + \frac{6h^2}{c^2T^2}} \approx 1 + \frac{3h^2}{c^2T^2}.$$

Hence, the resulting precession for a nearly circular orbit defined by (5.9) becomes

$$\phi = 2\pi(\alpha - 1) = \frac{6\pi h^2}{c^2T^2}. \quad (5.10)$$

Let us now apply (5.10) to the anomalous precession of Mercury's perihelion, one of the hallmark tests of general relativity. Since Mercury's orbit is nearly elliptical, we take advantage of the relations $h^2 = GMR$ and $R = T(1 - e^2)$ where T is the semi-major axis and e is the eccentricity to obtain (cf. [13] and [15])

$$\begin{aligned} \phi &= \frac{6\pi GMR}{c^2T^2} = \frac{6\pi GM(1 - e^2)}{c^2T} \\ &= \frac{6\pi(6.673 \times 10^{-11})(1.99 \times 10^{30})(1 - 0.2056)}{(2.9979 \times 10^8)^2 5.79 \times 10^{10}} \\ &= 4.6069 \times 10^{-7} \text{ radians/revolution.} \end{aligned} \quad (5.11)$$

Since Mercury makes approximately 415.2 revolutions per century, this leads to an anomalous precession of 39.45 arc-seconds per century and is in close agreement with the observed amount of 43 arc-seconds per century.

6 EINSTEIN'S COSMOLOGICAL CONSTANT

Einstein introduced the cosmological constant Λ into his field equations as a divergence-free term to allow for static solutions ([19], p. 155):

$$G_{ij} + \Lambda g_{ij} = 8\pi T_{ij}, \quad (6.1)$$

where $G_{ij} = R_{ij} - \frac{1}{2}Rg_{ij}$ is the Einstein tensor. In the absence of matter (6.1) reduces to

$$G_{ij} + \Lambda g_{ij} = 0. \quad (6.2)$$

It is well known that a flat space-time solution to (6.2) exists for positive Λ and is given by the de Sitter metric:

$$ds^2 = -\left(1 - \frac{1}{3}\Lambda r^2\right) dt^2 + \frac{1}{\left(1 - \frac{1}{3}\Lambda r^2\right)} dr^2 + r^2 d\theta^2 + r^2 \sin^2 \theta d\phi^2 \quad (6.3)$$

As before we can identify the Newtonian potential Φ corresponding to (6.3) in the weak-field case as

$$\Phi = \frac{(g_{00} + 1)}{2} = \frac{\Lambda}{6} r^2. \quad (6.4)$$

Thus the force exerted by this potential on a test particle of mass m is

$$F = -m \frac{d\Phi}{dr} = -\frac{\Lambda}{3} mr. \quad (6.5)$$

For positive Λ the cosmological force in (6.5) is repelling (recall Newton's convention regarding a negative force) and since it permeates throughout space (if it exists at all), this implies an accelerated expansion of the universe. It is this expansion and the vacuum energy that drives it that has made the cosmological constant the leading candidate for dark energy, an attempt to explain the anomalous acceleration (recession) observed in galaxies, one of the hottest unresolved issues in physics today ([9], [11]).

If we therefore assume the existence of a cosmological force in addition to the Newtonian force due to the gravitational attraction between m and M , then the resulting force law is (per unit mass)

$$F_{\Lambda}(r) = \frac{GM}{r^2} - \frac{\Lambda}{3} r. \quad (6.6)$$

Comparison of the two force laws F_c and F_{Λ} given by (4.13) and (6.6) clearly shows that Newton's extraneous force corresponds precisely to Einstein's cosmological force.

7 REVOLVING GENERAL RELATIVISTIC ORBITS

Equation (4.6) can be viewed as an approximation of precession based on Newtonian mechanics and revolving elliptical orbits. However, it is also possible to develop a second-order approximation based on revolving general relativistic (GR) orbits. To this end, let $r(\theta)$ be a GR-orbit obeying the force law

$$F_E(r) = \frac{GM}{r^2} + \frac{3GMh^2}{c^2 r^4} = \frac{GMr^2 + 3GMh^2 / c^2}{r^4}. \quad (7.1)$$

Then a revolving GR-orbit must follow the modified force law

$$\tilde{F}_E(r) = F_E(r) + \frac{\tilde{h}^2 - h^2}{r^3} = \frac{GMr^2 + 3GMh^2 / c^2 + (\tilde{h}^2 - h^2)r}{r^4}. \quad (7.2)$$

Now given any arbitrary force law $F(r)$ in the form

$$F(r) = \frac{C(r)}{r^4} \quad (7.3)$$

we can again compute precession as in Section 4 for a nearly circular orbit by assuming $r = T - X$ with T and X as before. Then approximating $F(r)$ to second-order (quadratic) in X ,

$$\begin{aligned} F(r) &= \frac{C(r)}{r^4} = \frac{C(T - X)}{r^4} \\ &\approx \frac{C(T) - C'(T)X + C''(T)X^2 / 2}{r^4}, \end{aligned} \quad (7.4)$$

and identifying it as $\tilde{F}_E(r)$, we equate (7.2) and (7.4) to obtain

$$C(T) - C'(T)X + C''(T)X^2 / 2 = GM(T - X)^2 + 3GMh^2 / c^2 + (\tilde{h}^2 - h^2)(T - X).$$

Thus,

$$\begin{aligned} C(T) &= GMT^2 + 3GMh^2 / c^2 + (\tilde{h}^2 - h^2)T, \\ C'(T) &= 2GMT + (\tilde{h}^2 - h^2), \\ C''(T) &= 2GM. \end{aligned} \quad (7.5)$$

Solving the first and second equations in (7.5) for the two angular momentums yields

$$\begin{aligned} \tilde{h}^2 &= C'(T) - 2GMT + \frac{c^2[C(T) - TC'(T) + GMT^2]}{3GM}, \\ h^2 &= \frac{c^2[C(T) - TC'(T) + GMT^2]}{3GM}. \end{aligned}$$

This leads to the following formula for precession:

$$\alpha^2 = \frac{\tilde{h}^2}{h^2} = 1 + \frac{3GM[C'(T) - 2GMT]}{c^2[C(T) - TC'(T) + GMT^2]}. \quad (7.6)$$

Observe that in the classical nonrelativistic limit where $c \rightarrow \infty$, i.e., the speed of light is assumed to be much greater than all other motions, we have

$$\lim_{c \rightarrow \infty} \alpha^2 = 1. \quad (7.7)$$

To determine the amount of precession, we apply Newton's Binomial Theorem as before:

$$\alpha \approx 1 + \frac{3GM[C'(T) - 2GMT]}{2c^2[C(T) - TC'(T) + GMT^2]}. \quad (7.8)$$

Therefore,

$$\phi = \frac{3\pi GM[C'(T) - 2GMT]}{c^2[C(T) - TC'(T) + GMT^2]}. \quad (7.9)$$

Observe from (7.9) that $\phi = 0$ if and only if $C'(T) = 2GMT$, i.e. $\tilde{h} = h$.

As an application, let us now determine the influence of the cosmological constant on precession of GR-orbits. The corresponding gravitational force law with nonzero Λ takes the form (see Section 6)

$$\begin{aligned} F(r) &= \frac{GM}{r^2} + \frac{3GMh^2}{c^2 r^4} - \frac{\Lambda}{3} r \\ &= \frac{GMr^2 + 3GMh^2/c^2 - \Lambda r^5/3}{r^4} \end{aligned} \quad (7.10)$$

In this case

$$\begin{aligned} C(T) &= GMT^2 + 3GMh^2/c^2 - \Lambda T^5/3, \\ C'(T) &= 2GMT - 5\Lambda T^4/3, \\ C''(T) &= -20\Lambda T^3/3. \end{aligned} \quad (7.11)$$

and so

$$\phi = -\frac{15\pi GM \Lambda T^4}{9GMh^2 + 4c^2 \Lambda T^5}. \quad (7.12)$$

Lastly by using the approximation $h^2 = GMT$, we obtain

$$\phi = -\frac{15\pi GM \Lambda T^3}{9G^2 M^2 + 4c^2 \Lambda T^4}. \quad (7.13)$$

To apply this formula to, say, Mercury's orbit, we use current accepted bounds on the cosmological constant which place it on the order ([8])

$$|\Lambda| < 10^{-45} \text{ km}^{-2}. \quad (7.14)$$

Since $4c^2 \Lambda T^4 \ll 9G^2 M^2$ for Mercury, we find (using Newton's Binomial Theorem once again) that

$$\begin{aligned} |\phi| &\approx \frac{5\pi T^3 |\Lambda|}{3GM} < \frac{5\pi (5.79 \times 10^{10})^3 \cdot 10^{-45}}{3(6.673 \times 10^{-11})(1.99 \times 10^{30})} \\ &< 7.65 \times 10^{-33} \text{ rad/revolution} \\ &< 6.55 \times 10^{-25} \text{ arcsec/century.} \end{aligned} \quad (7.15)$$

This shows the influence of the cosmological constant on precession of planetary orbits (beyond what can be accounted for by general relativity) to be quite negligible and unfortunately beyond current experimental detection (cf. [1], [14]).

ACKNOWLEDGMENT. I would like to sincerely thank my friend Eduardo Flores in the Physics and Astronomy Department at Rowan University for his helping in editing this article. It has been a joy to learn Einstein's theory of general relativity from him. I am also indebted to the referees for their helpful comments. Any remaining errors are of course solely my responsibility.

References

- [1] J. F. Cardona and J. M. Tejeiro, Can Interplanetary Measures Bound the Cosmological Constant?, *The Astrophys. J.* **493** (1998) 52-53.
- [2] S. Chandrasekhar, *Newton's Principia for the Common Reader*, Oxford University Press, 1995.
- [3] A. Cook, Success and failure in Newton's lunar theory, *Astronomy & Geophysics* **41** (2000) 21-25.
- [4] G. Gamow, *My World Line: An Informal Autobiography*, Viking Adult, 1970.
- [5] D. Goldfield, *Einstein's Greatest Blunder? The Cosmological Constant and Other Fudge Factors in the Physics of the Universe*, Harvard University Press, 1995.
- [6] A. Harvey and E. Schucking, Einstein's mistake and the cosmological constant, *Amer. J. Phys.* **68** (2000) 723-727.
- [7] A. W. Kerr, J. C. Hauck, and B. Mashhoon, Standard clocks, orbital precession and the cosmological constant, *Classical and Quantum Gravity* **20** (2003) 2727-2736.

- [8] C. S. Kochanek, Is There a Cosmological Constant?, *The Astrophysical J.* **466** (1996) 638-659.
- [9] R. Krishner, *The Extravagant Universe: Exploding Stars, Dark Energy, and the Accelerating Cosmos*, Princeton University Press, 2002.
- [10] I. Newton, *The Principia: Mathematical Principles of Natural Philosophy*, A New Translation by I. Bernard Cohen and Anne Whitman, University of California Press, 1999.
- [11] P. J. Peebles and B. Ratra, The cosmological constant and dark energy, *Reviews of Modern Physics* **75** (2003) 559-606.
- [12] B. Pourciau, Reading the Master: Newton and the Birth of Celestial Mechanics, this MONTHLY **104** (1997) 1-19.
- [13] P. Rowlands, A simple approach to the experimental consequences of general relativity, *Phys. Educ.* **32** (1997) 49-55.
- [14] M. Sereno and P. Jetzer, Solar and stellar system tests of the cosmological constant, *Phys. Rev. D* **73** 063004 (2006) 1-5.
- [15] B. Temple and C. A. Tracy, From Newton to Einstein, this MONTHLY **99** (1992) 507-521.
- [16] H. W. Turnbull, *The Correspondence of Isaac Newton: Volume II, 1676-1687*, Cambridge U. Press, 1960.
- [17] S. R. Valluri, P. Yu, G. E. Smith, and P. A. Wiegert, An extension of Newton's apsidal precession theorem, *Mon. Not. R. Astron. Soc.* **358** (2005) 1273-1284.
- [18] R. M. Wald, *General Relativity*, The University of Chicago Press, 1984.
- [19] S. Weinberg, *Gravitation and Cosmology*, John Wiley, 1972.
- [20] E. Weisstein, Two-Body Problem—From ScienceWorld, A Wolfram Web Resource, {HYPERLINK <http://scienceworld.wolfram.com/physics/Two-BodyProblem.html>}.
- [21] C. Wilson, On the origin of Horrocks's lunar theory, *J. Hist. Astronom.* **18** (1987) 77-94.
- [22] _____, The Newtonian Achievement in Astronomy, in *The General History of Astronomy: Volume 2 – Planetary Astronomy from the Renaissance to the Rise of Astrophysics*, Cambridge University Press, 1989.

Hieu D. Nguyen (Nguyễn Đức Hiếu) was born in Saigon, Vietnam, but grew up in St. Paul, MN. He received his B.S. in math and electrical engineering from the University of Minnesota in 1990. However, his inability to grasp the logic as to why the cut-off voltage of a diode is set at 0.7 volts convinced him to attend graduate school in math. He studied under Joseph A. Wolf at the University of California-Berkeley where he received his Ph.D. in 1996. Since then he has been teaching at Rowan University. His mathematical research is guided by Niels Abel's timeless advice, "It appears to me that if one wants to make progress in mathematics one should study the masters, and not the pupils." When not thinking about math, he enjoys spending time with his wife, Khanh, and their four children; the remaining ε amount of his time is devoted to playing tennis. *Department of Mathematics, Rowan University, Glassboro, NJ 08012*
nguyen@rowan.edu

Originally submitted to Monthly: 8-26-06
 Final revision: 1-30-07